



# OWNER'S OPERATION MANUAL

## EZ Loader Custom Boat Trailers



Preserve the appearance and performance of your EZ Loader Custom Trailer with these guidelines and recommendations. If a problem arises contact your dealer from whom the original purchase was made or visit [www.ezloader.com](http://www.ezloader.com).





EZ Loader Custom Boat Trailers is proud that you have chosen us as the transportation for your boat. Each trailer is individually made in Midway, Arkansas by skilled employees. The components used for your trailer are selected from the best marine and automotive vendors and are chosen because of their durability, strength and style. Our custom-welded trailers are welded by certified welders who have gone through extensive training. The finish on the trailers is sprayed on by experienced employees in our Finish Department with “DuPont Top Gun” training. EZ Loader holds numerous patents in the marine industry associated with the innovation of our products and we pride ourselves on the fit and construction of each trailer that can be found globally.

For the 2013 Custom model year we are introducing the “6 for 60” warranty\*. This warranty is in celebration of the 60th Anniversary of EZ Loader Boat Trailers which started in 1953. Your trailer warranty covers your trailer 6 years from the manufacturing date or 5 years from retail sale (which ever pertains). See the back cover for complete information.

Your satisfaction is our main objective because it is a reflection on each of our employees who come in contact your trailer. EZ Loader is the most widely distributed trailer in the marine industry.

*\*This warranty went into effect 7/1/13 for 2013 model year trailers and beyond.*

**Contact Information**

EZ Loader Custom Boat Trailers, Inc.  
PO Box 270  
Midway Arkansas 72651-0270

**870-481-5138**

**Warranty x239**

[customwarranty@ezloader.com](mailto:customwarranty@ezloader.com)

**Parts x254**

[customparts@ezloader.com](mailto:customparts@ezloader.com)

**E-Parts Store**

[www.ezloader.com](http://www.ezloader.com)

*(Choose Custom Lower Left)*

# **TABLE OF CONTENTS**

<b>Warnings</b>	<b>4</b>
<b>Introduction</b>	<b>5</b>
<b>Choosing the Right Trailer-Weight</b>	<b>5</b>
<b>Choosing the Right Trailer-Length</b>	<b>6</b>
<b>Trailer Length</b>	<b>6</b>
<b>Bunks vs. Rollers</b>	<b>6</b>
<b>Attaching Your Trailer</b>	<b>7</b>
<b>Hitch Recommendations</b>	<b>8</b>
<b>Coupler &amp; Hitch Ball Operation</b>	<b>9</b>
<b>Using Safety Chains</b>	<b>10</b>
<b>Tongue Jack Use &amp; Care</b>	<b>11</b>
<b>Trailer Lights</b>	<b>12</b>
<b>Winch Adjustment &amp; Use</b>	<b>12</b>
<b>Swing Tongue</b>	<b>13</b>
<b>On The Road</b>	<b>13</b>
<b>Launching &amp; Loading- Roller Trailers</b>	<b>15</b>
<b>Launching &amp; Loading- Bunk Trailers</b>	<b>17</b>
<b>Trailer Maintenance &amp; Storage</b>	<b>18</b>
<b>Wheel Maintenance &amp; Installation</b>	<b>19</b>
<b>Brakes</b>	<b>21</b>
<b>Wheel, Tire &amp; Hub Care</b>	<b>25</b>
<b>Tire Changing</b>	<b>25</b>
<b>Jack Placement</b>	<b>27</b>
<b>Tire Basics</b>	<b>27</b>
<b>Location of VIN</b>	<b>31</b>
<b>Trailer &amp; Loading Information</b>	<b>32</b>
<b>Tire Definitions</b>	<b>34</b>
<b>Trailer Definitions</b>	<b>36</b>
<b>MCO &amp; VIN Replacement</b>	<b>37</b>
<b>Canadian Registration Recall Document</b>	<b>37</b>
<b>Warranty Registration &amp; Reporting</b>	<b>38</b>
<b>Registration Information</b>	<b>39</b>
<b>Warranty</b>	<b>40</b>

**WARNINGS**

**THE FOLLOWING SIGNAL WORDS AND SYMBOLS ARE USED TO ALERT YOU TO POTENTIAL HAZARDS. OBEY ALL MESSAGES AND INSTRUCTIONS THAT FOLLOW THESE WORDS TO AVOID POSSIBLE INJURY OR DEATH.**



**DANGER** indicates an hazardous situation which, if not avoided, could result in death or serious injury.



**WARNING** indicates a potentially hazardous situation which, if not avoided, will result in death or serious injury.



**CAUTION** indicates a potentially hazardous situation which, if not avoided, may result in minor or moderate injury.



**NOTICE** used without the alert symbol indicates a potentially hazardous situation which, if not avoided, may result in property damage.

## Introduction

We would like to thank you for purchasing the best boat trailer made today, an EZ Loader Custom Boat Trailer. Since 1953, EZ Loader has been the industry leader in making quality boat trailers. All EZ Loader boat trailers are National Marine Manufacturers Association (NMMA) certified and National Association Trailer Manufacturers (NATM) compliant.

NMMA Certification means we comply with established industry standards and federal safety regulations. NATM verification compliance program verifies that trailers are built to meet best practices according to state and federal regulations. Both organizations require annual or bi-annual inspections of the facility and trailers.



EZ Loader Boat Trailers, Inc. manufactures trailers under their subsidiaries EZ Loader Custom Boat Trailers, Inc. (*For this document will be known as EZLC*) and EZ Loader Adjustable Sales Corporation, Inc. This manual deals specifically with custom welded trailers manufactured by EZLC.

Your new trailer is designed to make loading and launching your boat easier. Read this manual carefully before you use your trailer because it gives details on the trailer you just purchased. Pay attention to and follow all instructions and maintenance procedures in this manual.

We have a large dealer network across the United States, Canada and the world, making service available to you almost

everywhere.

Parts and accessories for your trailer can be purchased through your dealer, and directly from the EZLC Parts Department:

**870-481-5138 x254**

E-store:

**www.ezloader.com** (choose Custom)

## Choosing the Right Trailer

### Weight Capacity



**DO NOT exceed your vehicle's GVWR**

Choosing the right trailer to match your boat is very important. Your trailer not only has to be long enough and wide enough for your boat, but must be able to carry the weight of the boat and everything in the boat, including motor(s), fuel, water, personal gear, and other items that you may have on board. This final weight is called a "wet weight and cannot exceed the carrying capacity of the trailer. The GVWR (Gross Vehicle Weight Rating) listed for the trailer, is the maximum amount that the boat and trailer combined can weigh. Do not exceed your trailer's GVWR. If you don't know the weight of the boat when its fully loaded combined with the weight of the trailer, have it weighed.



**The weight of the boat, as listed in the boat manufacturer's product brochure, may not include the weight of the motors, fuel, water and personal gear and should not be used alone when choosing a trailer.**

## Trailer Length

### **NOTICE**

Make sure when the boat is on the trailer, there is enough space between the front of your boat and the back of your tow vehicle.

When choosing a trailer, make sure you take into account the boat's true transom to bow length. Some boats have a bow pulpit, an anchor chock or other hardware on the bow of the boat, which can extend several feet forward beyond the bow. The trailer tongue must be long enough to give you enough space between your boat and the towing vehicle, when loading the boat, turning a corner, or backing up so you do not hit your tow vehicle. A less than adequate distance between the boat and towing vehicle may allow them to contact each other causing excessive damage to both. Measure the length from the transom to the bow eye to make sure the winch stand can be moved forward or backward, as well as high and low, to meet the bow eye and still have the transom of the boat supported by the rear-most bunks.

### **Bunk vs. Roller**

There are 2 basic types of support systems on boat trailers: bunks or rollers. Bunk style systems have long support bunks, made of wood, with a carpet or a plastic-like surface. Roller systems generally have multiple sets of rollers to support the hull. Bunk trailers operate best on steep ramps where you are able to submerge the trailer deep enough to partially float the boat off and on the trailer. Roller trailers will function well on either shallow or steep ramps and will allow you to launch and load without putting the trailer in the water as deep as on a bunk style trailer. Some boat manufacturers specify which support system to use with their boats. Please see the "Launching and Loading" section on page 17 for further information.

## Supporting Your Boat's Weight

Roller and bunk trailers have different weight distribution characteristics. For roller trailers, your boat should rest evenly on the rollers. Once the rollers on your EZ Loader boat trailer have been adapted to your boat, the patented self-adjusting roller system will carry the weight of the boat evenly. The non-marking cushioned rollers protect your boat surface and supply the needed strength and support. The tongue/keel rollers and the side rollers should be adjusted where applicable. The transom of your boat should rest on the rear most roller. If your transom is left unsupported, severe damage may occur to your boat. Always use tie-down straps or similar approved securing devices to secure the boat to the trailer, as well as winch strap/cable and safety chains/cables supplied with your trailer. Do not allow the boat strakes to rest on a roller or bunk. Adjust the roller pattern on the left side of the trailer to mirror the roller pattern on the right side. Don't place rear rollers too far apart. If you do, you could hit the rear crossmember during launching or loading. If you suspect an adjustment problem, please contact your EZ Loader Dealer immediately.

Bunk trailer users should make sure that the long, straight bunks evenly carry the boat's weight. If one side of your boat is higher than the other side, you may need the bunk bracket adjusted by an authorized EZ Loader Dealer. The transom of your boat should be even or slightly forward with the back end of the bunk. If your transom is left unsupported severe damage may occur to your boat. If bow and center supports are used, make sure that no large amount of pressure is placed on the hull in any one spot, where flexing could occur. As with roller trailers, the bunks and hardware on the left side of your trailer should be the same as on the right side.

## Attaching Your Trailer



Before hitching your trailer to your tow vehicle, please check the items listed on the decal located on or near the winch stand. (See Figure 1 on right)

Your EZ Loader Dealer will provide another decal if it is missing or illegible.

Make sure the coupling device lever is up (coupler is open). Raise the front of the trailer with the tongue jack. Back your tow vehicle close to the trailer, then get out and check the location of the coupler and hitch ball. Move your tow vehicle until the coupler is over the hitch ball. Using the tongue jack, lower the trailer until the coupler completely covers the hitch ball. Lock the coupler (coupler lever is down).

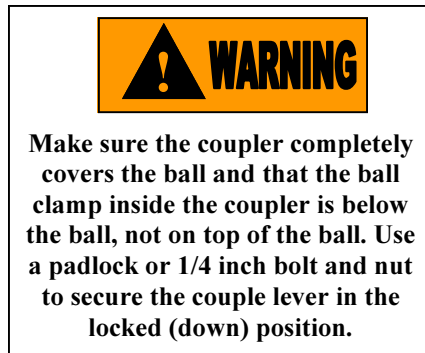

After the coupler is locked on the hitch ball, raise the front of the trailer using the tongue jack. If the coupler comes loose, open the coupler (lever up), attach the coupler to the hitch ball and raise the front of the trailer again. If the coupler will not stay attached, check the hitch ball and coupler for size and damage.

### **WARNING**

Death, serious injury, and / or property damage can result if you do not read and follow instructions in the owner's manual and this decal. Make sure all people towing this trailer read and follow the instructions. If you do not have an owner's manual, contact EZ Loader immediately to get a free replacement.

### **WARNING**

#### BEFORE TOWING THIS TRAILER CHECK THAT:

- Coupler and hitch ball are the same size and correct rating.
- Coupler is latched (closed).
- All safety chains are attached. The trailer safety chains are crossed under the tongue.
- All trailer lights are working correctly.
- Boat is secured to the trailer front & rear. (DO NOT use winch line alone).
- Tongue jack is all the way up and stored.
- Wheel lug bolts or nuts are tight.
- Tires have correct pressure.
- Trailer brakes are adjusted and breakaway cable is attached to tow vehicle.
- Load on trailer is within trailer capacity, distributed correctly, and the trailer tongue weight is correct.

### **WARNING**

This product contains chemicals known to the State of California to cause cancer and other birth defects or other reproductive harm.

### **CAUTION**

You are required to obey local and state laws and regulations regarding brakes, licensing, and additional equipment that is needed for your trailer. Contact your state motor vehicle department for more information.



Figure 1



After the coupler is secured to the hitch ball, raise the tongue jack all the way. If you have a swing-up style tongue jack, turn it to the traveling position and make sure the lock pin is secure in the hole. If your trailer does not have a tongue jack, you can buy one at your EZ Loader Dealer or at EZ Loader's on line parts store. ([www.ezloader.com](http://www.ezloader.com)).

Cross the safety chains or cables under the tongue and attach them to the tow vehicle. Connect the trailer wiring harness to the lighting system of your tow vehicle. Remember to check your lights. If electric brakes are used, make sure to connect the brake wiring to your tow vehicle's brake wiring.

Spot check all other trailer components (i.e.tires and tie-downs).

### Hitch Recommendations and Tips



**Make sure the jack is in the stored or traveling position before towing the trailer. If it is not, it can cause the trailer to separate from the tow vehicle. (See Fig 4-Page 11)**



**Your trailer's GVWR must not exceed the capacity of your hitch. Be sure you have the right size ball, shank, and capacity to match your trailer's model and coupler size. The correct ball size and capacity is marked on the coupler**

Two types of trailer hitches are normally used: Weight carrying hitches which attach to the tow vehicle and support the trailer tongue weight only, and weight distributing hitches which transfer some of the tongue weight to the tow vehicle by using extra spring bars on each side of the trailer ball. Bumper hitches are not recommended for boat trailers.

For most boat trailers, a weight-carrying hitch is usually adequate. Weight-distributing hitches are recommended for very heavy loads. Before you decide which hitch to buy, contact your EZ Loader Dealer and read the manufacturer's recommendations for your towing vehicle. EZ Loader does not recommend self-installation of trailer hitches.

If you choose a weight-distributing hitch, contact a dealer specializing in hitches and hitch installation to make sure it is properly installed, that it is compatible with your trailer's brake system and that you don't exceed weight requirements.



**Do not use weight-distributing hitches with surge-braked trailers. Overloading or improper installation of weight-distributing hitches may not let hydraulic surge brake actuators work and the tow vehicle and trailer may take longer to stop.**

Several models of weight distribution hitches will render the brakes inoperative. EZ Loader cannot assume responsibility or accept warranty claims in such instances. Please make sure the weight distribution hitch you choose is compatible with the trailer's braking system.



Please Note: Hitch ball height is determined by measuring from the ground to the top of the coupler ball housing with the trailer frame level when the trailer is on a level surface. The average height to the top of the hitch ball is usually from 14 inches to 21 inches above the ground when loaded. Actual height will vary from trailer to trailer.



**For proper load distribution on tandem and triple torsion axle trailers, it is very important that the trailer is parallel to the ground while towing.**

Every coupler on an EZ Loader boat trailers permanently marked with:

- A. Manufacturer's code, name or trademark;
- B. SAE coupling designation and gross coupler rating;
- C. Part number or style model; and Proper ball diameter.

### Coupler and Hitch Ball Operation



**Do not use a different size ball shank, or capacity than recommended and be sure both the hitch ball and hitch ratings are the same or more than the Gross Vehicle Weight Rating of your trailer.**

Keep the latch mechanism clean and lightly oiled.

If the latch mechanism or coupler is bent or deformed in any manner, do not use

the trailer until a new latch assembly or coupler is installed. Some replacement assemblies and rebuild kits are available at your EZ dealer or at EZ Loader's on-line store at [www.ezloader.com](http://www.ezloader.com).

EZLC trailers are equipped with several types of couplers. Examples of the of most popular are listed below. (Figure 2)

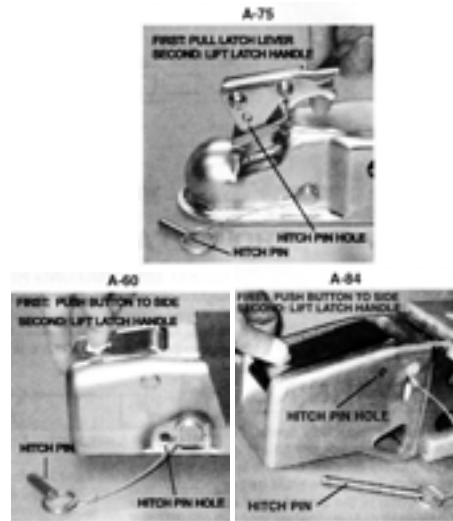

Figure 2

#### A-75 Opening

Remove hitch pin from hole on side of coupler latch handle. While lifting up on latch handle trigger, lift up on latch handle until it rotates about 90 degrees and stops. The coupler should unlatch easily. If not, the ball may be oversized or egg-shaped, foreign matter could be lodged in coupler ball socket, or the coupler is pushing on the hitch ball. Check to make sure the wheel on the tongue jack is not raised or that you are not parked downhill. Correct these conditions, then try to open the handle. Examples include tongue jack forcing front of trailer up or trailer pushing against tow vehicle. Correct as necessary.

#### A-75 Closing

Place coupler over the ball, lower coupler and close handle. Coupler handle should close with minimal force. If handle does not

close, ball is not fully inserted into socket, is oversized or eggshaped. DO NOT FORCE HANDLE. If necessary, replace ball with a quality unit that meets SAE specifications. Visually verify that ball is completely inserted into coupler socket by looking into hole on top of coupler body. Insert hitch pin into hole on side of coupler latch handle.

#### **A-60 / A-84 Opening**

Remove hitch pin from hole in the side of the coupler. Push button on top of handle to the side. While holding button to the side, raise handle by lifting front with two fingers. The coupler should unlatch easily. If not, the ball may be oversized or eggshaped, foreign matter could be lodged in coupler ball socket, or the coupler is pushing on the hitch ball. Check to make sure the wheel on the tongue jack is raised or that you are not parked downhill. Correct these condition, then try to open the handle. Examples include tongue jack forcing front of trailer up or trailer pushing against tow vehicle. Correct as necessary.

#### **A-60 / A-84 Closing**

Place coupler over the ball, lower coupler and close handle. You will hear a “click”. Handle should close with finger pressure. If handle will not close freely, ball is not fully inserted into socket, is oversized or eggshaped. DO NOT FORCE HANDLE. If necessary, replace ball with a quality unit that meets SAE specifications. Insert hitch pin into hole on side of coupler.



**You must install either the hitch pin (supplied) or (A-60 & A-75 only) a padlock (1/4” or 5/16” shank) into the hitch pin hole before towing to prevent the coupler latch opening accidentally.**

**DO NOT tow your trailer if latch handle will not remain closed or with the handle open. Check to see if coupler is locked by lifting up on the handle without pushing the button to the side before towing. If the handle opens, the hitch ball is not the right size, oversized, or eggshaped, or the latch parts have been damaged. If the latch is damaged, contact UFP for replacement parts at [www.ufpnet.com](http://www.ufpnet.com).**

For further information see actuator brochure in your new trailer packet or visit [www.ufpnet.com](http://www.ufpnet.com).



**Always attach the trailer and boat bow safety chains before towing.**

#### **Using Safety Chains**

Your trailer hitch should have a place to attach the trailer safety chains or cables. Crisscross the trailer safety chains or cables under the trailer tongue before attaching to the towing vehicles. (See Figure 3) Most state laws require the crisscrossing of these chains or cables. This may prevent the trailer tongue from falling to the road in the event that the trailer coupler becomes detached from the hitch ball. Do not connect the trailer safety chains or cables together.

Original trailer safety chains or cables should not be removed or tampered with. Should you need to replace them, contact EZ Loader or your EZ Loader Dealer for replacement chains or cables and hooks.

*Fig. 3 Proper attachment of the safety chains/ cables is essential to trailer safety.*



### Tongue Jack Use and Care

Place the jack into position, crank the jack handle until the trailer coupler is high enough for the coupler to go over the hitch ball and lower the trailer coupler onto the ball by cranking the jack handle in the opposite directions.



**Back your tow vehicle to your trailer. DO NOT move your trailer to the tow vehicle. When the trailer is moved without a tow vehicle the brakes do not work.**

If your jack is a swing up type, return it to its stowed (up) position, making sure the securing pin is firmly in its hole. (See Figure 4) If your jack is not a swing-up type, retract your trailer jack completely (wheel raise as high as possible) before towing the trailer.



**Care must be used when engaging or disengaging a swing-up style tongue jack.**

When using the jack in the down position to support weight, make sure the securing pin is firmly in its hole before adding any weight to the jack. If the securing pin is not firmly in its hole, the jack may collapse under the weight placed on it. While towing if your jack is not folded up or retracted completely, damage could result and your jack may have to be replaced.

Like the winch, or any kind of mechanical assembly, a jack requires lubrication maintenance. Regularly grease the drive gear, and rack & pinion-and oil the caster and wheel bearings.



*Fig.4: Swing Jack in traveling position.*

### Trailer Lights



**Always check your trailer lights to make sure they are in working order before any trip. If your trailer has electric brakes, unplugging the trailer wire from the tow vehicle will disable the trailer brakes.**

Your EZ Loader boat trailer is equipped with the best lighting system available. Always double-check your lights to make sure they are in working order before any trip.

Twice a year, it is a good idea to inspect your taillights and look for bare wires, cracked insulation or corroded terminals. Always be sure the white ground wire is connected to the trailer frame. Replace all worn or damaged parts.

Waterproof grease, petroleum jelly, or WD-40® should be put on plug contacts and bulb bases to prevent rust and corrosion.

Tow vehicles with three-light lighting system (different lights for brake, turn, and tail lights) need an adapter to change the

three-light system to a two-light system. Make sure your vehicle is equipped with the proper lighting package. We recommend that a professional, i.e. your automotive dealer, install it for you. EZ Loader's Wire Color Code is listed to the top right in Figure 5.

**LED & Incandescent Lighting**

Your EZLC trailer is equipped with either LED or Incandescent lights. Incandescent lights put out about 90% of energy as heat and 10% as light, while LED's put out approximately 30-40% as light with a small amount of heat. LED's are energy efficient and have a longer life.



*Incandescent Light*

*LED Light*

**Wire Color Code**

White	Ground
Brown	Taillights, Side Marker Lights
Yellow	Left Brake, Left Turn
Green	Right Brake, Right Turn
Blue	Back Up Solenoid, Reversing Light

*Fig. 5 EZ Loader Wire Color Code*

**Before You Tow  
Tying Down Your Boat**



Tie down the boat securely at the stern, in both a downward and forward direction, with approved tie downs. Use the rear tie-down points provided on your trailer.

Make sure your boat is properly secured to the trailer. Do not depend on the winch line, strap or cable alone to hold your boat secure. Check winch line, strap or cable for fraying, cuts or tears. If it is damaged, replace it immediately. **DO NOT USE IF DAMAGED!**

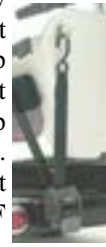

**Winch Adjustment and Use**



Whether your winch is a hand-operated model (standard) or an electric model (aftermarket), both can be adjusted for the best possible performance. The winch height should be adjusted so that the winch cable/strap is level or as close as practical with the bow eye of the boat when the boat is resting on the trailer, with the bow stop roller or vee block just above the bow eye of the boat. Your boat will then be pulled in straight line onto the trailer and against the bow stop on the winch stand. The angle the winch is pulling your boat should not make the boat lift up or pull down when pulling the bow eye against the underside of the bow roller or vee block. It should pull the bow eye straight into the underside of the bow roller or vee block. (See Figure 6)

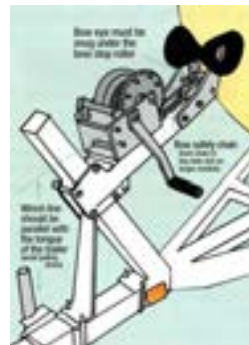

*Fig. 6  
Proper  
Winch  
Operation*

Maintenance of the mechanical winch is simple. Keep clean, lubricate regularly and apply heavy grease to the gears frequently. Make sure the winch line, strap or cable doesn't rub against anything sharp; fraying and wear could result. If your line, strap or cable becomes worn, contact your EZ Loader Dealer for replacement as soon as possible or visit EZ Loader's on line store at [www.ezloader.com](http://www.ezloader.com).

### Swing Tongue

EZLC offers a variety of swing tongue applications. Our standard trailers usually have the pivot type application in which the pin is pulled from one side and the bolt holds the other side so that the tongue can turn at least 90 degrees. The inline swing tongue is a EZLC designed product with our manufacturer hides the bolts and hinge inside the application giving it a much nicer appearance. The inside is a cast zinc plated-piece that allow for the part to be opened without scratching the paint. This also has a pin application and bolt. In 2013 it includes a lubrication zerk fitting that allows for better maintenance and turning ability.



### On the Road

EZ Loader recommends all people wear appropriate safety restraints at all times while towing with any vehicle.

Going too fast is a major cause of vehicle trailer accidents. At a minimum, observe the posted speed limits. Slow down for curves, bad weather, hazardous road condition and expressway exits. Do not feel secure if you trailer tows easily at higher speeds. A road hazard that could be avoided at 45 or 50 mph, may not be at 55mph.

### Stopping/Following Distance

Your tow vehicle and trailer are heavier and longer than your tow vehicle alone. This means it will take you longer to stop. Allow at least 4 seconds between you and the vehicle in front of you. Start counting when the back of the vehicle in front of you passes a fixed object, such as a sign post, telephone pole, or crack in the road. If the front of your vehicle reaches the object before the end of the 4 seconds, slow down to increase the distance. Then check the following distance again. If you are driving in bad weather, such as rain, snow or fog. Use at least a 5 second gap.

### Hills

To prevent your tow vehicle's engine from lugging when going up hills, shift into lower gears. This will improve gas mileage and reduce engine overheating.

Swaying or "fishtailing" happens more often going downhill. To prevent this from happening, decrease speed **BEFORE** going down the hill. If your trailer has surge brakes, do not shift into lower gears when going downhill. This can make the trailer brakes come on the whole time you are going downhill and may cause your trailer brakes not to work.

**DO NOT** ride the brake pedal going downhill. When you need to slow down, press the brake pedal and slow down at least 5 mph below the speed limit. Then let completely off the brake pedal and let the brakes cool before you press the brake pedal again if possible or practical.

## Passing

Your tow vehicle and trailer are heavier and longer than your tow vehicle alone and you will need more time and distance to pass.

Passing by another vehicle in the same or opposite direction can cause sway or fishtailing. This sway is greater when your speed is higher. See the SWAY/FISHTAILING section below on what to do if this happens.

## Sway/Fishtailing

One or more causes (cross winds, passing vehicles, quick driver steering actions, improper loading, excessive speed, etc.) may result in sway. During sway, applying your brakes or turning the steering wheel can cause a jackknife, loss of control or both.

If sway happens:

Let off the gas pedal, NEVER speed up to try to control sway.  
DO NOT apply your brakes.  
Steer straight ahead, enough to keep in your lane. DO NOT try to control sway by turning the steering wheel.

After the swaying has stopped:

- ⚠️ Pull a safe distance off the roadway and stop. Get all the occupants out and away from the vehicle.
- ⚠️ Check the cargo in your boat to make sure it has not shifted. Also make sure the trailer is loaded heavier in the front.
- ⚠️ Check that all the tires are properly inflated and all lug bolts or nuts are tight.
- ⚠️ Check the trunk or cargo bed of the tow vehicle to make sure it is not overloaded.
- ⚠️ **DRIVE AT A SLOWER SPEED.** Sway happens most often at higher speeds.

## Road Shoulders

Sometimes the trailer is wider than the tow vehicle. Drive in the center of the lane to allow for a wider trailer. If wheels of your vehicle or trailer go off the paved roadway:

- ⚠️ Hold the steering wheel firmly.  
Let off the gas pedal and slow down below 25 mph.
- ⚠️ DO NOT apply the brakes.
- ⚠️ DO NOT turn the steering wheel sharply.
- ⚠️ After slowing down below 25 mph, gradually turn the steering wheel just enough to get you back on the roadway.
- ⚠️ Proceed with caution when entering traffic.
- ⚠️ Dropping off the shoulder may cause alignment issues with the trailer axle.

## Backing

To back your trailer, keep your hand at the bottom of the steering wheel. To move the trailer left, move your hand left. To move the trailer right, move your hand right. If your tow vehicle and trailer starts to jackknife, or is not headed where you want it, STOP. Pull forward to straighten out, and then start again.

## Breakdowns & Accidents

### Get Off the Road

If something goes wrong and you need to get off the road, immediately park your tow vehicle in a safe place, as far away from the road as possible. Turn on your emergency flashers. Get all the occupants out of the vehicle and away from the roadway.

If you must continue on the road to reach a safe place off the road, turn on your emergency flashers, slow down and proceed with caution.



Do not hesitate to drive on a flat tire if it is necessary to reach a safe place completely off the roadway. Drive slowly, since the scraping tire and wheel could cause a fire.

### **Getting In and Out of the Water**

The handling of your boat and trailer at the ramp requires practice, skill and patience. With care and attention to the following tips, you can launch and load your boat with relative ease.

Always prepare the boat for launching before you get to the ramp. Stop in a launching prep area near the ramp that does not block traffic and remove your tie-downs, tilt up your engine or drive unit, replace your transom drain plugs, etc.

Do not disconnect the wiring harness, winch cable or optional boat bow safety chain until you are by the water, ready to launch. You do not need to disconnect the electric trailer brakes before launching the boat. If you disconnect the electric trailer brakes, the trailer brakes will not work.



**If the winch handle slips out of your hand, let it spin.  
DO NOT try to stop it.  
This could cause bodily harm.**

Bunk style trailers with composite or plastic surfaces on the bunks (such as Channel Glide Bunk Covers) are very slippery. Extra caution should be taken while removing the winch strap/cable and safety chains as the boat may start to unload at the same time.

EZ Loader manufactures both “Roller” type trailers and “Bunk” type trailers. Please follow the launching and loading directions for the type of trailer you purchased.

### **Roller Trailers- Launching and Loading**

With EZ Loader’s unique roller technology, you have one of the easiest ways in the world to launch and load your boat. Back the trailer down the ramp to the water. (See Backing section on page 16). If there is not a ramp available, use a solid area of ground next to the shore, with a slope if possible. Avoid wet, soft sand.

With your boat & trailer backed down to the water and in a “launch-ready” position, remove the boat bow safety chain from the boat. Hold the winch handle securely, reverse the winch lock and begin unwinding the line. Unwind it slowly and carefully.

Tie a mooring line to the boat to help you control it in the water average grade ramp, the rollers on your trailer will allow your boat to gently roll back into the water. Do not remove the boat bow safety chain or winch lock until the boat and trailer are located in “launch” position.

If your boat does not immediately move, try unwinding about six inches of line, **lock your winch** and give the boat a push. Then unlock the winch and try again. Your boat should roll safely into the water.

When loading, always prepare for the procedure prior to reaching the ramp. If the ramp is busy, preparation will shorten the time it takes for you to get your boat out of the water.

Make sure your engine or drive unit is in the full up position. Just as in the launching procedure, do not put your trailer wheels or brakes in the water, if possible. For the self-adjusting and centering rollers to work properly, they must not be too far under water. (See Figures 7, 8 and 9-Page 16)





Fig 7 Launching from a Roller Trailer on a steep ramp



Fig 8 Launching from a Roller Trailer on an average grade ramp



Fig 9 Launching from a Roller Trailer on a shallow ramp

### Loading Your Boat (Roller Trailers)

Unlock your winch and unwind enough cable/strap to attach the hook to the bow eye of your boat. For safety, always keep at least three turns of cable/strap around the winch drum. Never let your cable/strap all the way out. Lock your winch before attempting to wind the cable/strap in.

Thanks to EZ Loader's marvelous roller technology, you don't need to have the boat in perfect alignment with the trailer. Fasten the boat to the winch line and start winding. The self-adjusting rollers will automatically center your boat and align it to its correct angle. Strong wind and current can affect the automatic adjusting capability of your roller trailer, so be aware of those conditions while loading. Optional load guides can help you keep your boat

centered in adverse conditions. Pull the bow eye tight to bow roller or vee block. Connect the boat bow safety chain and you are ready to drive to the loading/preparation area near the ramp to connect all other tie-downs, lighting or electric brake connections, etc.

### Launching Checklist

#### In the Parking Area

- Remove the trailer-to-motor supports.
- Remove tie-downs.
- Load and store gear that goes on the boat.
- Check all systems, including your boat's engine, blower, bilge pump and lights.
- Disconnect trailer wiring when you are by the water and ready to launch from your tow vehicle.  
*(Leave the wiring attached if you have EZ Loader cab-controlled electric brakes. Disconnect will eliminate braking capability.)*
- Remember to properly install all drain plugs.

#### At the Ramp-in Launch Position

- Disconnect the bow safety chain hook for the bow eye.
- Following launching instructions.
- Always practice good boating.



### **Bunk or Custom Trailers- Launching & Loading**

You can rest assured that your new EZ Loader bunk style custom-welded, adjustable or aluminum trailer is engineered to provide the easiest launching/loading experience possible.

Back the trailer down the ramp until there is enough water to make the boat float. Because the bunks generate more friction than rollers, you need to back the trailer further into the water. Tie a mooring line to the boat so you will have control once it is floating.

Unfasten the boat bow safety chain. Hold the winch handle securely, reverse the winch lock and begin unwinding the line. Unwind it slowly and carefully

**WARNING**

**If the winch handle slips out of your hand, let it spin.  
DO NOT try to stop it.**

On an average grade, the bunks on your trailer will allow your boat to gently slip back and float into the water. If your boat does not immediately move, try unwinding about six inches of line, lock your winch and give the boat a push. Then unlock the winch and try again. If this does not work you might try backing the trailer in deeper if possible. (See Fig. 10)



Fig 10 Launching from a Bunk Trailer on an average grade ramp

Care should be given when launching from trailers with bunks that are equipped with Channel Glide Bunk Covers or other plastic like materials. These materials make the bunk surfaces very slippery, and the boat may begin to unload as soon as tension is released on the winch cable/strap.

If the boat will still not unload, it is likely that your trailer needs adjusting. Contact your EZ Loader Dealer as soon as possible.

When loading, always prepare for the procedure prior to reaching the ramp. If the ramp is busy, preparation will shorten the time it takes for you to get your boat out of the water.

You probably will not have to back the trailer into the water as far to load the boat as you did to launch it. In fact, the easiest way is to back your trailer up until the rear of the bunks are in the water. By not putting your trailer too deep in the water, your boat will actually center itself on the bunks about 1/3 to 1/2 the distance onto the trailer.

Connect the winch cable/strap to the bow eye of the boat. Lock your winch before attempting to wind the cable/strap in. Once your boat is aligned and is pulled firmly against the winch stand roller or vee block and your winch is in the locked position, connect the boat bow safety chain and you are ready to drive to the loading/preparation area near the ramp to connect all other tie-downs, lighting or electric brake connections, etc.

### **Common Causes of Boat Misalignment**

If your boat does not sit level in the water or your bunks or rollers are not adjusted properly, you may have misalignment problems with your boat when loading.

**Correction Procedures for boat misalignment:**

1. For custom fitted bunk trailers, that you feel are misaligned, contact your EZLC dealer.
2. Re-measure all roller assemblies that set in a line across from each other. Make sure the distance to each roller from the centerline of the trailer is equal. In other words, the left side of your trailer should be exactly the same as the right side. This is true of bunk or roller trailers.
3. If your boat keeps going to the port (left) side, remove the boat and loosen the U-bolts and/or the through bolts that clamp the roller assemblies on the stern (back) section of the trailer. Force each assembly to the right as if you were trying to turn the handlebars of a bicycle. Hold each assembly in this turned position and retighten the U-bolts and/or through bolts.

This repositioning of the roller assemblies should correct the misalignment of the boat on your trailer. If your boat goes toward the starboard (right) side, reverse the procedure.

4. Another common reason for boats not centering themselves is putting the trailer too deep in the water, which does not allow the trailer adequate time to center the boat. This is especially true on roller style trailers. If problems persist, contact your EZ Loader Dealer as soon as possible.

*Please Note: Make sure your trailer is not too deep in the water or the boat will float over the rollers and be difficult to load and center.*

**Trailer Maintenance and Storage**

One of the best maintenance procedures for your trailer is washing the trailer with soap and rinsing with fresh water after every use. This will help prevent rust and give your trailer that “showroom” appearance for a long time.

People often forget to give their trailer the same waxing care as their car, but if you want your trailer to last, wax it on a regular basis. Touch up all scratches and spots of rust as soon as they occur. Matching paint can be obtained by your EZLC Dealer or contact the EZLC Parts Department at:

**800-553-7855 x239 or  
customparts@ezloader.com.**

Check your tire pressure (when tires are cold) and make sure they are inflated to the correct pressure. (See tire information on page 28) Tires can lose considerable amount of air pressure when stored during non use. It is recommended that during storage, trailers be blocked up with the tires off the ground. *Note: Underinflated tires can cause wear and tear problems.*

Every trip, check your lug nuts or bolts for tightness on your wheels. Once a year, or every 2000 miles, whichever comes first, check your greased hub bearings (see page 25). Check your light wires and electric brake wiring (if applicable) for damage and make sure they do not hang down where they could be caught. Check your new trailer warranty package.

Flush kits are available for drum style brakes and will help to keep the brakes clean, especially in saltwater or brackish waste areas.

When parked or stored, insure brake actuator is fully extended to release brakes and master cylinder push rod.

**A handy hint:** A little petroleum jelly in the light bulb sockets creates a better seal, prevents corrosion and makes it easier for replacement, if ever necessary. L.E.D. lights require no maintenance.

If you have a roller trailer, periodically grease the shafts of the rollers and roller assembly. Lubricate the winch latch assembly and gears. Watch for frayed cables, straps or ropes and replace them as soon as possible.

For off-season storage, park your boat and trailer in a protected area, such as a garage or carport. Do not put plastic bags around your light fixtures condensation will occur and cause corrosion.

While your boat is in storage, it is a good time to touch up any rust spots, nicks and chips on your boat and trailer. Galvanized trailers occasionally show small rust spots, so touch up those spots with cold galvanizing spray paint, available at most paint stores.

A little trailer maintenance goes a long way in preserving the appearance and performance of your trailer. Please follow our recommendations. We want you to have your EZ Loader boat trailer for a long, enjoyable time.

### **Tuff Coat Finish**

This is a sprayed on polyurea. It is sprayed over a fully primed frame structure, offered by EZLC that protect the surface of the trailers against rock chips. Special repair kits are available at [customparts@ezloader.com](mailto:customparts@ezloader.com).



Boat bottom cleaners containing muratic or other acids have a highly corrosive effect on both painted, galvanized or aluminum trailers and should not be allowed to contact the trailer.

### **Wheel Maintenance**

All warranty claims will be voided if improper maintenance or improper cleaning agents are used. Your investment in a product of the highest quality and workmanship do require care to maintain their factory appearance.

### **Regular Cleaning**

Typical road soils trap moisture, which can cause corrosion over a period of time. Brake dust, caused by friction of your trailers braking system, is itself corrosive and may cause pitting of the wheel finish. These soils must be removed regularly, possibly weekly, depending on your trailering habits.

### **Use of Proper Cleaning Agents**

Your wheels finish should be treated as you would treat the finish of your car. All one-piece aluminum wheels, and two piece aluminum wheels are clear coated to preserve the finish and ease of cleaning. Most household cleaning agents are too harsh for the finish on your wheel and must be avoided. There are commercially available wheel cleaners, but we urge extreme caution regarding their use, since they tend to be acid or lye based. Always follow the manufacture's recommendations on the bottle for safe and effective cleaning.

*Note: Salt water can cause discoloration of aluminum wheels. This is not covered by your warranty.*

### **Chrome Steel Wheels**

After cleaning, always apply a coat of soft non-abrasive cream wax to help prevent surface corrosion. Surface corrosion or rust can be prevented with proper care.

### **Additional Tips**

To prevent scratching of the wheel finish, never clean your wheels with scouring pads or mag polish. If you use automatic car washes, tell them not to use steam cleaners or strong chemicals to clean your wheels. They can cause permanent staining or corrosion.

### Additional Tips (Continued)

Use caution when cleaning tires with steel wool or bristle brush. These types of abrasive materials must not come in contact with the wheels. Never allow any harsh chemicals or tire cleaner to contact with the wheels, as they will damage the appearance of the wheel permanently. Never spray cold water on extremely hot wheels. Always allow time to cool before cleaning with soap and water or the recommended wheel cleaner.

### Wheel Installation

- Clean and inspect all stud threads and mounting surfaces before installation. Threads must not be lubricated, but must be free of corrosion, rust, burrs and fractures. Replace studs if they are corroded beyond reasonable repair, if threads are stripped, or a fracture is found. Check and make sure the approved lug nuts are correct for the application. When placing the wheel on the studs, there will be an apparent looseness of fit, until the lug nuts are applied.
- Check the lug nut thread engagement. Every stud must be long enough to thread into the lug nut a length at least equal to the stud diameter. For example: a 1/2" thread diameter must thread into the lug nut at least a 1/2". Check for this problem on every stud, some may be different lengths. Less than one stud thread engagement, do not install wheels.
- Lug nuts must be applied in a star or crisscross pattern until desired torque is reached. (See Figure 11)

### Wheel Alignment

A wheel alignment adjusts the angles of the wheels so that they are positioned correctly relative to the vehicle's frame. This adjustment maximizes the life of your tires. These adjustments require special equipment and should be performed by a qualified technician.

### Tire Repair

The proper repair of a punctured tire requires a plug for the hole and a patch for the area inside the tire that surrounds the puncture hole. Punctures through the tread can be repaired if they are not too large, but punctures to the sidewall should not be repaired. Tires must be removed from the rim to be properly inspected before being plugged and patched.

### Check All Nuts and Bolts

Even though EZ Loader uses self-locking, vibration resistant nuts, it is the owner's responsibility to make sure all of the fasteners are tight before using the trailer not just the first time you use it, but on a regular basis.



### Lug Bolt or Nut Tightening Method

Initially tighten to 20-25 lbs., using a criss-cross tightening sequence on a 5 bolt wheel. (See figure 11.)

Finish torquing per manufacturer's recommendations on all new trailers. EZ Loader is not responsible for damage from loose lug nuts. Re-torque after 25-50 miles of use and on a periodic schedule from then on. Lug bolts or nuts should be clean and dry. Do not put grease or other lubricant on them.

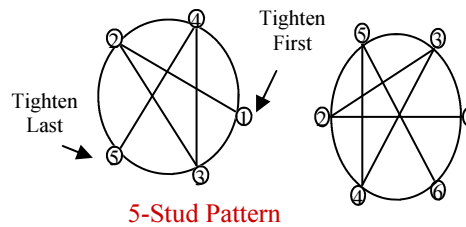

Fig. 11 Lug Bolt Order



**Most state laws require brakes on trailers check laws in your state.**

Always keep tie-downs tightly fastened. Always use tie-downs or similar securing devices to secure the boat to the trailer, as well as the winch strap/cable and safety chains/cables supplied with your trailer.

### **Trailer Braking Systems**

EZLC offers four different braking systems; Hydraulic surge (drum brakes), hydraulic surge (disc brakes), electric (drum brakes) and electric over hydraulic. All four braking systems offer excellent trailer braking, but each have unique qualities.

### **Hydraulic Surge (Drum Brakes)**

Hydraulic surge drum brakes have been the boat trailer standard for decades. These trailer brakes are dependable and quick to react, are independent of the tow vehicle, and come on automatically when you press the brake pedal in the tow vehicle. As the tow vehicle slows down, the trailer wants to keep moving forward. This moves the brake actuator and applies the trailer brakes. This “surge” action is where the surge brakes get their name. (See Figure 12)

### **Hydraulic Surge (Disc Brakes)**

Hydraulic surge disc brakes operate on the same idea as hydraulic surge drum brakes. The disc brake needs a special actuator with a back-up solenoid wired into the tow vehicle’s reverse lights. When the tow vehicle is put in reverse, the solenoid locks out the braking system allowing the trailer to back up on level ground without the brakes locking up. Since you can see most of the disc brake components, they are easy to keep clean and maintain. (See Figure 13) See the brochure in your new trailer

packet for further information or visit [www.ufpnet.com](http://www.ufpnet.com)

### **Electric (Drum Brakes)**

Electric trailer brakes are not hydraulic and are not independent of the tow vehicle. Since this system does not have hydraulic parts, it is easier to install on the trailer. With electric brakes, the driver can adjust the amount of braking on the trailer and can apply the trailer brakes alone by using the brake controller mounted in the tow vehicle. The brake controller is an additional part and must be put in the tow vehicle for electric brakes to work. The brake controller senses when the tow vehicle is slowing down and puts on the trailer brakes. This type of braking system also works when backing up the trailer. In addition to the brake controller in the tow vehicle, electric brakes must have a battery on the trailer in case the trailer is disconnected from the tow vehicle while it is moving. (See Figure 14)



**Electric brakes must have a brake controller in the tow vehicle and another charged battery on the trailer**

### **Electric Over Hydraulic Brakes**

Electric Over Hydraulic brakes have an actuator that is powered by the battery in your tow vehicle. They are controlled by the power supplied to the brake lights of the tow vehicle. As the brakes are applied on the tow vehicle, the brake lights are signaled. This activates the electric over hydraulic system on the trailer, which creates pressure on the brake fluid in the system that is supplied to the wheel cylinders or calipers causing the brakes to apply on the trailer.



## Brake Operation and Maintenance



In many states trailers are required to have brakes on all wheels.

Contact your state motor department, your EZLC Dealer or another possible source is [http://www.boatus.com/trailerclub/trailer\\_laws.asp](http://www.boatus.com/trailerclub/trailer_laws.asp) for the trailer brake requirements in your state.

A brake flush kit is recommended for boat trailers subject to saltwater or brackish water situations. Flush kits for drum brakes will help increase the life of the brake components in salt-water areas. These kits are available from your EZ Loader Dealer or at the on-line store at [www.ezloader.com](http://www.ezloader.com).

Inspect your brake system on a regular basis and adjust if necessary and replace any damaged or worn parts. Your EZLC Dealer can also inspect your brakes. Replace brake fluid with DOT3, which is available from most auto parts stores. Trailer brake manufacturers recommend that when the boating season is over, the brake drums should be removed and the brake assembly should be inspected. All parts should be clean, dry and free from corrosion.

An EZ Loader Dealer can check the brakes, clean the shoes, backing plate and the rest of the parts. A rust inhibitor product application is often suggested by manufacturers. Reassemble drum and wheel components. EZ Loader recommends trailers with drum brakes to be inspected and a rust inhibitor applied at least once a year.

With hydraulic brakes, do not shift to a lower gear and use your engine as a brake when going downhill. This could activate the trailer's brakes continuously for the duration of the downhill run, causing overheating and

fading to the point of possibly losing your trailer's braking ability completely.

A better way is to slow down as you approach the top of the hill, and maintain an even, slow, controlled downhill speed with repeated applications of your tow vehicle's brakes, allowing enough time in between for the brakes to cool off.

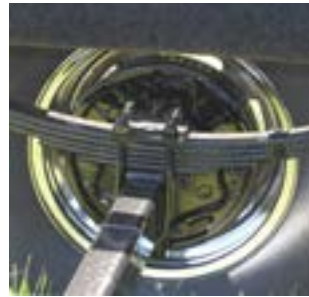

*Fig. 12 Hydraulic Drum Brakes*



*Fig. 13 Hydraulic Disc Brakes*



*Fig. 14 Electric Brakes*



## Brake Adjustment



**Drum style brakes are NOT self-adjusting brakes and will require regular checking and adjustment from time to time to make sure they operate properly.**



**Using pads and shoes without enough brake lining material can result in brake damage, create excessive heat and cause the brakes not to work correctly.**



**Make sure the trailer cannot move. Attach it to the tow vehicle and block the tires when servicing the brakes.**

**Only a qualified mechanic trained in the repair and maintenance of braking systems should attempt brake adjustment, repair and replacement.** To make the brake adjustments to your EZ Loader trailer, follow the method explained below. If you are not sure about making these adjustments, your EZ Loader Dealer can make these adjustments for you. See the Jack Placement section on page 27 for instructions.

### For Hydraulic Drum Brakes

1. Raise the trailer wheel so it can turn freely.
2. Locate and remove the dust cover from the adjusting slot on the lower back of the brake backing plate.

3. Locate the brake adjusting screw (called a star adjuster) through the adjusting slot and insert a brake adjusting tool. Adjust the brake shoes out (tighten by turning the star adjuster down on the left side drum and up on the right side drum) until tires will not turn by hand, then back off (loosen by turning the star adjuster up on the left side drum and down on the right side drum) the adjustment until the wheel turns freely, usually 8 to 10 clicks. Rotate the drum in the direction of forward rotation only. (See Figure 15)
4. If properly adjusted the drum should turn freely and have a barely audible sound of the shoes against the drums. This indicates that the shoes are in contact with the drum, but not dragging.



**The star adjuster can disconnect from the brake and fall to the bottom of the brake drum if you loosen it too much. This will cause damage to the brake and will not let the brakes work properly.**

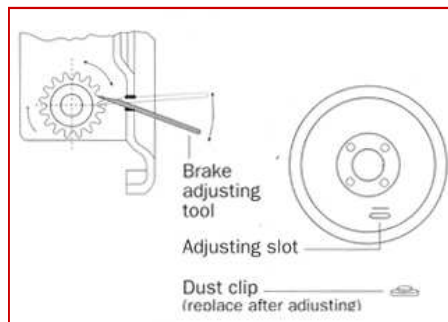

Fig. 15

## Trouble-Shooting Hydraulic Brakes

### SYMPTOM

### SOLUTION

#### BRAKE NOISE

- |                                                            |                                                                                              |
|------------------------------------------------------------|----------------------------------------------------------------------------------------------|
| Shoe chatter, lining coated with grease or oil.            | ➤ Locate cause of grease or oil leakage, reline and grind for proper lining-to-drum contact. |
| Vibration with loose bolts, out-of-round drums.            | ➤ Tighten hub bolts or nuts and recondition or replace drums.                                |
| Vibrations with loose bearing adjustment or rough bearing. | ➤ Adjust or replace bearings and races.                                                      |
| Worn/cracked drums or machined beyond oversize limits.     | ➤ Replace drums.                                                                             |

#### EXCESSIVE TRAVEL OF ACTUATOR

- |                                                                                                                                                              |                                                                       |
|--------------------------------------------------------------------------------------------------------------------------------------------------------------|-----------------------------------------------------------------------|
| Leaks in hydraulic lines.                                                                                                                                    | ➤ Replace defective lines.                                            |
| Low fluid in master cylinder reservoir.<br>Air in hydraulic lines.                                                                                           | ➤ Refill master cylinder and bleed system.                            |
| Leaking wheel cylinders.                                                                                                                                     | ➤ Repair or replace.                                                  |
| Leaking primary cup in master cylinder. Ports closed or restricted with dirt. Defective hoses. Leaking check valve fails to keep hydraulic system preloaded. | ➤ Check problem components and adjust, repair or replace as required. |
| Excessive lining-to-drum clearance.                                                                                                                          | ➤ Adjust brakes or replace linings.                                   |

#### PRESSURE BUILD-UP IN SYSTEM

- |                                                                                   |                                                                   |
|-----------------------------------------------------------------------------------|-------------------------------------------------------------------|
| Contaminated fluid causing cup swelling.                                          | ➤ Drain, flush and replace fluid. Replace cups.                   |
| Master cylinder piston fails to stop and keeps the compensating port closed.      | ➤ Check all components and adjust, repair or replace as required. |
| Hose or cylinder ports are closed or restricted with dirt.<br>Weak return spring. | ➤ Overhaul or replace.                                            |

#### HEAVY CLUNKING SOUND FROM ACTUATOR

- |                                          |                                            |
|------------------------------------------|--------------------------------------------|
| Leaks in hydraulic lines.                | ➤ Replace hydraulic lines.                 |
| Low fluid in master cylinder.            | ➤ Refill master cylinder and bleed system. |
| If no hydraulic leaks & good fluid level | ➤ Replace shock absorber.                  |

### Wheel, Tire and Hub Care

Since your EZ Loader boat trailer is put in water and put through other severe conditions, it needs more attention to the wheels and its components than your car. Your EZLC trailer is equipped with either of two hub systems, The Vault Hybrid Lubrication System™ or EUz hubs. (See Figure 16)

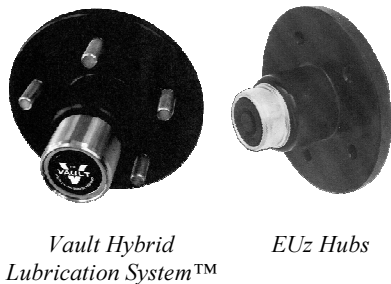

Fig. 16

Your EZLC trailer may be equipped with an axle utilizing the 5 year, no maintenance required “Vault™” bearing protector with specially formulated “Hybrid Oil” lubricant. There is no need for replenishment of the lubricant. Adding or changing the lubricant in the Vault is not necessary or recommended for the first five(5) years of service.

The EUz Bearing Lube Axle System does require continued maintenance. For the bearing protector to function properly, hubs must be completely filled with grease. Passages inside the spindle allow grease to flow into the space between the inner bearing and seal. As grease is added, it will flow through the bearings toward the front of the hub. Grease prior to towing and after launching or retrieval every time. Add grease to expel any water or contaminants that may enter hub cavity during hub submersion.

To answer any questions or need further information visit <http://www.ufpnet.com/Axles>. or see the brochures in your new

To check your bearings, raise your wheel clear of the road surface (by the procedure indicated in “tire changing”). With your hands on the outside edges of the tire, try to rock the wheel by pushing on one side and pulling on the other. No noticeable rocking should occur. Spin the wheel and listen for noise or roughness. A smooth, silent operation means that your bearings are in good order. If a grinding sound is heard, contact your EZ Loader Dealer for warranty and or replacement instructions.

Grease carefully with a hand operated grease gun before launching or storage. Do not add grease when the hub is cold because too much grease flow can damage seals and brake shoes. Do not use a power assisted grease gun.

Hubs must be completely filled with grease in order for the bearing protectors to function properly. Use certified waterproof lithium-based marine trailer bearing grease.

#### **DO NOT OVERFILL WITH GREASE.**

Some EZ Loader trailers are factory equipped with a bearing protector that uses a spring loaded piston to slowly feed grease through the bearing protector and into the bearings. On these models, this spring is plainly visible to the user. A zirc (grease) fitting is attached to the center of a disc located on the bearing protector. The disc is about the size of a half dollar. As you add grease to the bearing protector through the zirc fitting, the cavity slowly fills up and the disc will start to move towards you as it begins to compress the spring. Stop adding grease when the spring begins to compress and the disc begins to move towards you.

Do not fill the bearing protector until the spring is fully compressed. This can result

in damage to the seal, loss of the grease, and potential race, bearing and spindle damage. Periodic checking can be accomplished by simply rocking the disc side to side with your fingers. If the disc is able to rock side to side, it is floating on grease and no more grease needs to be added. If the disc has bottomed out (seated) and cannot be moved, it is time to add more grease using the instructions above.

If you have to remove a greased system bearing protector, lay a block of wood against the side of it and tap the wood with a hammer. Then place the wood on the opposite side and tap again. Continue until you “walk” the protector out of the hub. To install a bearing protector, make sure you have the proper sized bearing protector to match your hub. Then line the protector up with the hub, lay a block of wood over the front of the protector and tap the wood with a hammer. Bearing protectors are designed to fit tightly into the hub, so be sure it is carefully aligned before striking the wood.

*Note: Bearing Protectors are not a replacement for proper bearing maintenance.*



**Since boat trailer wheels are put in water, it is important you check and grease your wheel bearings on a regular basis.**

**Do not use a power-assisted grease gun to add bearing grease. Caution should be used when adding grease. Using a power-assisted grease gun or over-greasing the bearing protectors can cause the seal to fail.**

**Hubs must be completely filled with grease in order for the bearing protectors to work properly.**

### Periodic Drum Brake Adjustment

1. Adjust trailer brakes after the first 1000 miles of use.
2. Trailer brakes should be inspected and adjusted at the beginning of each boating season, or every 2000 miles, whichever comes first.
3. Wheel bearings and seals should also be inspected at this time.

### For Disc Brakes

Adjustment is not necessary on EZ Loader’s disc brakes. Make sure the brake parts are free from rust and debris. Check brake pads periodically to make sure there is a proper amount of lining left. Check the brake fluid and make sure it is full before every trip.

Only a qualified mechanic trained in the repair & maintenance of braking systems should attempt brake adjustment, repair and replacement.

### Tire Changing



**Make sure you are on a solid footing and level ground when changing tires.**

Replace your trailer tires promptly if they become worn or damaged. If within the warranty period, contact the tire manufacturer for an adjustment. (See Page 39) You can get a spare tire at your EZ Loader Dealer or online at [www.ezloader.com](http://www.ezloader.com). We also recommend that you carry a jack, such as a small hydraulic jack for tire changes.



Getting your hands in tight places under the fender can cause accidental pinching. We recommend wearing gloves while changing tires. After the tire is changed, be sure to re-torque the lug bolts or nuts as mentioned in the “Torque Procedure” section. To change a tire, make sure the trailer is not allowed to move. Attach it to the tow vehicle and block a tire on the opposite side.



**Do not mount or attempt to mount anything other than the same size tires on the same size wheel (rim) per manufacturer specifications.**  
*Example 16.5” tire on a 16.5” wheel.*

### Jack Placement



**Make sure the trailer is not allowed to move. Attach it to the tow vehicle and block the tires.**

On tubular steel type trailers, the best place to put your tire jack is under the axle where the spring mounts to the axle. On a torsion axle trailer, place the jack under the axle tube as near the tire as possible, but not on the torsion arm. If the jack will not fit under the axle, place it under the main frame rail (boom) as close to the axle as possible. On aluminum I-Beam trailers, the only allowable place to place the jack is under the axle as mentioned above.

**EZ Loader wheel sizes are as follows:**

8"	5 Hole	4 1/2" Bolt Circle
10"	5 Hole	4 1/2" Bolt Circle
12"	5 Hole	4 1/2" Bolt Circle
13"	5 Hole	4 1/2" Bolt Circle
14"	5 Hole	4 1/2" Bolt Circle
15"	5 Hole	4 1/2" Bolt Circle
15"	6 Hole	5 1/2" Bolt Circle
16"	6 Hole	5 1/2" Bolt Circle
16.5"	8 Hole	6 1/2" Bolt Circle
18"	5 Hole	4 1/2" Bolt Circle
20"	5 Hole	4 1/2" Bolt Circle

Figure 17

### Tire Basics

Properly maintained tires improve the steering, stopping, traction and load-carrying capability of your vehicle. Underinflated tires and overloaded vehicles are a major cause of tire failure. To avoid flat tires and other types of tire failure, you should maintain proper tire pressure, observe tire and vehicle load limits, avoid road hazards, and regularly inspect your tires.

### Finding Tire Pressure and Load Limits

Tire information placards and vehicle certification labels contain information on tires and load limits. These labels indicate the vehicle manufacturer’s information including:

- Recommended tire size.
- Recommended tire inflation pressure
- Vehicle capacity weight (VCW-the maximum weight the axle systems are designed to carry.)

*Both placards and certification labels are permanently attached to the front of the trailer. (See figures 21 & 22)*

## Tire Pressure

Tire inflation pressure is the level of air in the tire that provides it with load-carrying capacity and affects the overall performance of the vehicle. The tire inflation pressure is a number that indicates the amount of air pressure—measured in pounds per square inch (psi) a tire requires to be properly inflated. You will also find this number on the vehicle information placard expressed in kilopascals (kpa) which is the metric measure used internationally.)

The worst enemy a tire can have is too little inflation pressure. It can reduce fuel economy through increased rolling resistance (soft tires makes your vehicle work harder). When a tire is under inflated, the shoulder of the tire tread bears the most of the load and reduces tread-life through increased tread wear on the outside edges (or shoulders) of the tire. It also generates excessive heat, which reduces tire durability. Uneven wear reduces the useful life of a tire. Check your tires regularly for proper inflation. Abnormal tire wear may also be due to misalignment or mechanical problems.



It is important to check your vehicle's tire pressure at least one a month for the following reasons:

- Most tires may naturally lose air over time. As air pressure is lost, carrying capacity is lowered.
- Tires can lose air suddenly if you drive over a pothole or other object or if you strike the curb when parking.
- With radial tires, it is usually not possible to determine under inflation by visual inspection.

Tire Description	PSI	Capacity
P275/45R20 *	44	1903 lbs.
255/45ZR18 *	50	1753 lbs.
255/45ZR18XL *	50	1753 lbs.
ST175/80D13C	50	1360 lbs.
ST175/80R13C	50	1360 lbs.
ST185/80D13C	50	1480 lbs.
ST205/75D14C	50	1760 lbs.
ST205/75D15C	50	1820 lbs.
ST205/75R14C	50	1760 lbs.
ST205/75R14C	50	1760 lbs.
ST205/75R15C	50	1820 lbs.
ST215/75D14C	50	1870 lbs.
ST215/75R14C	50	1870 lbs.
ST225/75D15C	50	2150 lbs.
ST235/60R14C	50	1820 lbs.
4.80X12B	60	785 lbs.
ST225/75D15D	65	2540 lbs.
ST225/75R15D	65	2540 lbs.
5.30X12C	80	1050 lbs.
ST145/R12E	80	1520 lbs.
ST225/75R15E	80	2830 lbs.
ST235/85R16E	80	3640-S/3200-D
ST235/80R16E	80	3420-S/3000-D
4.80X12C	90	990 lbs.
* Derated P/CFR49		

*Fig. 18 Recommended Cold Tire Pressure Chart*

## Check Tire Pressure



**Keep your tires inflated to the recommended tire pressure on the VIN decal (found on the front rail of your trailer). Check the tire pressure before each trip.**



**Measuring and Adjusting  
Air Pressure to Achieve  
Proper Inflation**

The recommended tire inflation pressure that vehicle manufacturers provide reflects the proper psi when a tire is cold. (See Figure 18) The term cold does not relate to the outside temperature. Rather, a cold tire is one that has not been driven on for at least 3 hours. When you drive, your tires get warmer, causing the air pressure within them to increase. Therefore, to get an accurate tire pressure reading you must measure tire pressure when the tires are cold or compensate for the extra pressure in warm tires.

Before each trip, check the air pressure of each tire. Be sure to check the air pressure in the spare tire as well.

**Adverse safety consequences of  
under-Inflation**

Under-inflation of the tire cannot only wear-out the tire prematurely, but can also cause the tire to flex and to overheat quickly. Overheating of the tires can cause tread separation and tire failure. Tire separation or tire failure could lead to loss of control of the trailer and could lead to an accident.

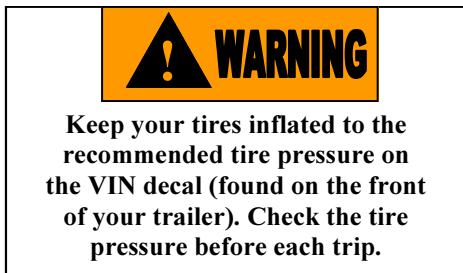

**Maintaining Proper Tire Pressure**

•Locate the recommended tire pressure on the vehicle’s tire information placard, certification label, or in the owner’s manual.

- Record the tire pressure on all tires.
- If the tire pressure is too high in any of the tires, slowly release air by gently pressing on the tire valve stem with the edge of you tire gauge until you get to the correct pressure.
- If the tire pressure is too low, note the difference between the measured tire pressure and the correct tire pressure. These ”missing” pounds of pressure are what you will need to add.
- At a service station, add the missing pounds of air pressure to each tire that is underinflated.
- Check all the tires to make sure they have the same air pressure (except in cases in which the front and rear tires are supposed to have different amounts of pressure).

If you have been driving your vehicle and think that a tire is underinflated, fill it to the recommended cold inflation pressure indicated on your vehicle’s tire information placard or certification label. While your tire may still be slightly underinflated due to the extra pounds of pressure in the warm tire, it is safer to drive with air pressure that is lightly lower than the vehicle manufacturer’s recommended cold inflation pressure than to drive with a significantly underinflated tire. Since this is a temporary fix, don’t forget to recheck and adjust the tire’s pressure when you can obtain a cold reading.

**Tire Fundamentals**

Federal law requires tire manufacturers to place standardized information on the sidewall of all tires. This information identifies and describes the fundamental characteristics of the tire and also provides a tire identification number for safety standard certification and in case of a recall. (See Figures 19 & 20.)





Fig. 19: Tire labeling

### Tire Information

There are many markings found on the sidewall of a tire. They are placed there by the tire manufacturer.

**ST**-Indicates the tire is for trailer use only.

**Next Number**- This three digit number gives the width in millimeters of the tire from sidewall edge to sidewall edge. In general, the larger the number, the wider the tire.

**Next Number**- This two digit number, known as the aspect ratio, gives the tire's ratio of height to width. Numbers of 70 or lower indicate a short sidewall for improved steering response and better overall handling on dry pavement.

**R**- The "R" stands for radial. Radial ply construction of tires has been the industry standard for many years.

**Next Number**- This two-digit number is the wheel or rim diameter in inches. If you change your wheel size, you will have to purchase new tires to match the new wheel diameter.

**U.S. DOT Tire Identification Number**-This begins with the letters "DOT" and indicates that the tire meets all federal standards. The next two numbers or letters are the plant code where it was manufactured, and the last four numbers represent the week and year the tire was built. For example, the numbers 3197 means the 31st week of 1997. The other numbers are marketing codes used at the manufacturer's discretion. This information is used to contact consumers if a tire defect requires a recall.

**Tire Ply Composition and Materials Used**- The number of plies indicates the number of layers of rubber-coated fabric in the tire. In general, the greater the number of plies, the more weight a tire can support. Tire manufacturers also must indicate the

materials in the tire, which include steel, nylon, polyester and others.

**Maximum Load Rating**- This number indicates the maximum load in kilograms and pounds that can be carried by the tire.

**Maximum Permissible Inflation Pressure**-This number is the greatest amount of air pressure that should ever be put in the tire under normal driving conditions.

### RADIAL TIRES

*(Using a ST205/75R14C as an example)*

- ST** Special Trailer type tire
- 205** Nominal width of the tire in millimeters  
*(205 millimeters in this example)*
- 75** Aspect ratio, (ratio of height to width)  
*(75% in this example)*
- R** Radial Tire
- 14** Size of Wheel *(14" in this example)*
- C** Load Range Rating

### BIAS PLY TIRES

*(Using a 530x12 C as an example)*

- 530** Width across the tire  
*(5.30 inches in this example)*
- 12** Size of Wheel  
*(12" in this example)*
- C** Load Range Rating

Fig. 20 Tire size labeling information

### Tire Size

Your trailer may be equipped with either radial or bias ply tires. The tire size labeling on bias ply tires is different than those on radial tires. It is important to understand the tire labeling on your tire when selecting tire or replacement tires for your trailer.

To maintain tire safety, purchase new tires that are the same size as the vehicle's original tires or another size recommended by the manufacturer. Look at the tire information placard, the owner's manual, or the sidewall of the tire you are replacing to find this information. If you have any doubt about the correct size to choose, consult with the tire dealer.

## Tire, Care, Maintenance, and Safety Practices

Before each trip, check each tire for:

Uneven wear

Nails or other sharp objects

Correct tire air pressure

Tread separation

Tread depth

Proper tightening (torque) on the lug bolts or lug nuts

Tire checking

- Check Tire pressure regularly (at least once a month), including spare.
- Inspect tires for uneven wear patterns on the tread, cracks, foreign objects, or other signs of wear or trauma.
- Remove bits of glass and foreign objects wedged in the tread.
- Make sure your tire valves have valve caps.
- Check tire pressure before going on a long trip.
- Do not overload you vehicle. Check the Tire Information and Loading Placard or User's Manual for the maximum recommended load for the vehicle.

Bulges or other deformities of the sidewall of the tire.

***If any of the above conditions exist, do not use the trailer until the condition is corrected.***

## Preventing Tire Damage

- Slow down if you have to go over a pothole or other object in the road.
- Do not run over curbs or other foreign objects in the roadway, and try not to strike the curb when parking.

## Vehicle Placard and Tire Inflation Pressure Label Information and Location

The Vehicle Placard and Tire Inflation Label are affixed to the forward part of the trailer near where the main frames meet the tongue. (Figures 20 and 21)



VIN # & TIRE Inflation Pressure Label Information Location

EZ Loader Custom Trailer's VIN number begins with **IL8**

(Prior to 2004 also IDH).

*EZ Loader Adjustable Trailer's VIN begins with **IZE** call 509-489-0181 for info.*



Fig. 21: Vehicle Placard (Example)



**Poor weight distribution can cause trailer sway (“fishtailing”) and put extra force on your boat, trailer, towing equipment and tow vehicle.**

4. Subtract the empty weight of your trailer from the GVWR stated on the VIN label. That weight is the maximum available cargo capacity of the trailer and may not be safely exceeded.



**Make sure the total weight of the trailer, boat, engine, fuel, batteries and gear does not exceed the trailer’s GVWR.**

**Determining load limits**

The load limit on a boat trailer is referred to as carrying capacity. The carrying capacity of your EZ Loader trailer must be more than or equal to the weight of the boat and everything in or on the boat, including motor(s), fuel, water, personal gear and other items you may have on board. The final weight of all these items is called a “net weight” and must not exceed the carrying capacity of the trailer.

The carrying capacity should not be confused with the GVWR rating of the trailer. The GVWR (Gross Vehicle Weight Rating) listed for the trailer is the maximum allowable combined weight of the trailer, boat, motor, fuel and gear. (See page 5, Choosing the Right Trailer.)

**Do not Exceed Load Carrying Capacity or GVWR**

The weight capacity of your trailer is found using the Gross Vehicle Weight Rating (GVWR) of the trailer. The GVWR is printed on the Vehicle Identification Number (VIN) decal at the right front of the trailer (viewing trailer from the rear). This is the MOST weight the fully loaded trailer can weight.

1. Locate the statement, “The weight of cargo should never exceed XXX kg or XXX lbs.”, on your vehicle’s placard.
2. Determine the empty weight of your trailer by weighing the trailer using a public scale or other means.
3. Locate the GVWR of the trailer on your trailer’s VIN (Certification) label.

When loading your cargo, be sure it is distributed evenly to prevent overloading front to back and side to side. Heavy items should be placed low and as close to the axle positions as reasonable. Too many items on one side may overload a tire. The best way to know the actual weight of the vehicle is to weigh it at a public scale.

TIRE AND LOADING INFORMATION			
The weight of cargo should never exceed 1271KG or (2800LB)			
TIRE	SIZE	COLD TIRE PRESSURE	
FRONT	ST205/75R14C	345 KPA	(50 PSI)
REAR	ST205/75R14C	345 KPA	(50 PSI)
SPARE	ST205/75R14C	345 KPA	(50 PSI)

**SEE OWNER'S MANUAL FOR ADDITIONAL INFORMATION**

*Fig. 22: Tire Information Pressure Label (Example)*

Talk to your dealer to discuss the weighing methods needed to capture the various weights related to the trailer. This would include the weight empty or unloaded, weights per axle, wheel, hitch or king-pin and total weight.

The trailer must not be connected to the tow vehicle when you get the total weight of the trailer. It is up to you to make sure the weight of your boat, trailer, and boat cargo does not exceed the GVWR. (See page 28)

Proper load distribution on your trailer is also very important. Tongue weight should be no less than 5% of recommended of specific GVWR and not to exceed the tongue weight capacity of the hitch. Five to ten percent of your trailer's Gross Vehicle Weight should be supported by the hitch ball, with the tongue level. This is call "tongue weight".

If you are over or under the standard weight distribution, try moving gear inside your boat first. If further adjustment to the trailer is necessary, contact your EZ Loader Dealer.



**Your trailer's GVWR must not exceed the capacity of your hitch.**



**Make sure the total weight of the trailer, boat, engine, fuel, batteries, and gear does not exceed the trailer's GVWR.**



**Check with your EZ Loader Dealer or automotive dealer to make sure you have the proper towing vehicle for the load you will be pulling. Check your vehicle manufacturer's hitch weight recommendations as well. Be sure you have the right size ball, shank and capacity to match your trailer's model and coupler size. The correct ball size and capacity is marked on the coupler.**

### **Locating the Load Limit Information**

The manufacturers VIN label has both the carrying capacity and the GVWR (Gross Vehicle Weight Rating) of your trailer. It also has tire size, cold tire pressure, VIN number, date of manufacture and other important information. The VIN label is located on the trailer frame towards the front end of the trailer rail. (See the example of the manufactures VIN label on page 29.)

### **Understanding How Cargo Affects Trailer Capacity**

The cargo or gear placed inside a boat while on a trailer adds to the GVW (Gross Vehicle Weight) of the trailer, and uses some of the capacity that may be available for the boat. The combined weight of the gear, boat, as well as anything else in or on the boat while trailering must not exceed the carrying capacity listed for your trailer.

Excessive loads and/or underinflation cause tire overloading and, as a result, abnormal tire flexing occurs. This situation can generate an excessive amount of heat within the tire. Excessive heat may lead to tire failure. This is the air pressure that enables a tire to support the load, so proper inflation is critical. The proper air pressure may be found on the certification/VIN label and/or on the Tire Placard. This value should never exceed the maximum cold inflation pressure stamped on the tire.



Poor weight distribution can cause trailer sway (“fishtailing”) and put extra force on your boat, trailer, towing equipment and tow vehicle.

### Adverse Safety Consequences of Overloading on Handling, Stopping and on Tires



DO NOT exceed your vehicle’s GVWR

Overloading the trailer could produce the following:

- Increased stopping distances
- Improper tongue weight
- Abnormal or premature tire wear
- Tire failure
- Suspension failure
- Decreased cornering stability
- Brake overheating or failure
- Undue stress or failure of trailer components
- Hull damage

**Never exceed the trailer’s listed GVWR**

### Determining Compatibility of Tire and Vehicle Load Capabilities

The proper tire for your EZ Loader Boat Trailer is listed on the VIN label on the trailer. Replacing a tire with any tire other than the size and type indicated on the VIN label should not be done. Each tire has a maximum load capacity printed on the sidewall.

The combined sum of the load capacities of all the tires of the trailer should meet or exceed the GVWR listed on the VIN label of the trailer. The Original Equipment Tires are designed to meet these requirements.

### Tire Terminology

**Bead:** The part of the tire that is made of steel wires, wrapped or reinforced by ply cords and that is shaped to fit the rim.

**Bead Separation:** This is the breakdown of the bond between components in the bead.

**Bias Ply Tire:** A pneumatic tire in which the ply cords that extend to the beads are laid at alternate angles substantially less than 90 degrees to the centerline of the tread.

**Carcass:** The tire structure, except tread and sidewall rubber which, when inflated, bears the load.

**Chunking:** The breaking away of pieces of the tread or sidewall.

**Cold Inflation Pressure:** The pressure in the tire before you drive for at least 3 hours.

**Cord:** The strands forming the plies in the tires.

**Cord Separation:** The parting of cords from adjacent rubber compounds.

**Cracking:** Any parting within the tread, sidewall, or the inner liner of the tire extending to cord material.

**CT:** A pneumatic tire with an inverted flange tire and rim system in which the rim is designed with rim flanges pointed radially inward and the tire is designed to fit on the underside of the rim in a manner that encloses the rim flanges inside the air cavity of the tire.

**Curb Weight:** The weight of a motor vehicle with standard equipment including the maximum capacity of fuel, oil and coolant, and, if so equipped, air conditioning and additional weight optional engine.

**Extra Load Tire:** A tire designed to operate at higher loads and at higher inflation pressures than the corresponding standard tire.

**Groove:** The space between the adjacent tread ribs.

**Gross Axle Weight Rating:** The maximum weight that any axle can support, as published on the Certification/VIN label on the front left side of the trailer. Actual weight determined by weighing each axle on a public scale, with the trailer attached to the towing vehicle.

**Gross Vehicle Weight Rating:** The maximum weight of the fully loaded trailer, as published on the Certification/VIN label. Actual weight determined by weighing trailer on a public scale, without being attached to the towing vehicle.

**Hitch Weight:** The downward force exerted on the hitch ball by the trailer coupler.

**Innerliner:** The layer(s) forming the inside surface of a tubeless tire that contains the inflating medium within the tire.

**Innerliner Separation:** The parting of the innerliner from cord material in the carcass.

**Intended Outboard Sidewall:** The sidewall that contains a white-wall, bears white lettering or bears manufacturer, brand, and /or model name molding that is higher or deeper than the same molding on the other sidewall of the tire or the outward facing sidewall of an asymmetrical tire that has a particular side that must always face outward when mounted on a vehicle.

**Light Truck (LT) Tire:** A tire designated by its manufacturer as primarily intended for use on lightweight trucks or multipurpose passenger vehicles.

**Load Rating:** The maximum load that a tire is rated to carry for a given inflation pressure.

**Maximum Load Rating:** The load rating for a tire at the maximum permissible inflation pressure for that tire.

**Maximum Permissible Inflation Pressure:** The maximum cold inflation pressure to which a tire may be inflated.



## Tire Terminology

**Maximum Loaded Vehicle Weight:** The sum of curb weight, accessory weight, vehicle capacity weight and production options weight.

**Measuring Rim:** The rim on which a tire is fitted for physical dimension requirements.

**Non-Pneumatic Rim:** A mechanical device which, when a non-pneumatic tire assembly incorporates a wheel, supports the tire, and attaches, either integrally or separably, to the wheel center member and upon which the tire is attached.

**Non-Pneumatic Spare Tire Assembly:** A non-pneumatic tire assembly intended for temporary use in place of one of the pneumatic tires and rims that are fitted to a passenger car in compliance with the requirements of this standard.

**Non-Pneumatic Tire:** A mechanical device which transmits, either directly or through a wheel or wheel center member, the vertical load and tractive forces from the roadway to the vehicle, generates the tractive forces that provide the directional control of the vehicle and does not rely on the containment of any gas or fluid for providing those functions.

**Non-Pneumatic Tire Assembly:** A non-pneumatic tire, alone or in combination with a wheel or wheel center member, which can be mounted on a vehicle.

**Normal Occupant Weight:** This means 68 kilograms (150 lbs.) times the number of occupants specified in the second column of Table 1 of 49 CFR 571.110.

**Pin Weight:** The downward force applied to the 5th wheel or gooseneck ball, by the trailer kingpin or gooseneck coupler.

**Occupant Distribution:** The distribution of occupants in a vehicle as specified in the third column of Table 1 of 49 CFR 571.110.

**Open Splice:** Any parting at any junction of tread, sidewall, or innerliner that extends to cord material.

**Outer diameter:** The overall diameter of an inflated new tire.

**Overall Width:** The linear distance between the exteriors of the sidewalls of an inflated tire, including elevations due to labeling, decorations, or protective bands or ribs.

**Ply:** A layer of rubber coated parallel cords.

**Ply Separation:** A parting of rubber compound between adjacent plies.

**Pneumatic Tire:** A mechanical device made of rubber, chemicals, fabric and steel or other materials, that, when mounted on an automotive wheel, provides the traction and contains the gas or fluid that sustains the load.

**Production Options Weight:** The combined weight of those installed regular production options weighting over 2.3 kilograms (5 lbs.) in excess of those standard items which they replace, not previously considered in curb weight or accessory weight, including heavy duty brakes, ride levelers, roof rack heavy duty battery, and special trim.

**Radial Ply Tire:** a pneumatic tire in which the ply cords that extend to the beads are laid at substantially 90 degrees to the centerline of the tread.

**Recommended Inflation Pressure:** This is the inflation pressure provided by the vehicle manufacturer on the Tire Information label and on the Certification /VIN tag.

**Reinforced Tire:** A tire designed to operate at higher loads and at higher inflation pressures than the corresponding standard tire.

**Rim:** A metal support for a tire or tire and tube assembly upon which the tire beads are seated.

**Rim Diameter:** This means the nominal diameter of the bead seat.

**Rim Size Designation:** This means the industry of manufacturer's designation for a rim by style or code.

**Rim Type Designation:** This means the industry of manufacturer's designation for a rim by style or code.

**Rim Width:** This means the nominal distance between rim flanges.

**Sidewall Width:** The linear distance between the exteriors of the sidewalls of an inflated tire, excluding elevations due to labeling, decoration or protective bands.

**Sidewall:** That portion of a tire between the tread and bead.

**Sidewall Separation:** The parting of the rubber compound from the cord material in the sidewall.

**Special Trailer (ST) Tire:** The "ST" is an indication the tire is for trailer use only.

**Test Rim:** The rim on which a tire is fitted for testing, and may be any rim listed as appropriate for use with that tire.

**Tire Checking:** Small cracks in the tire sidewall usually associated with age or sitting in intense sunlight conditions.

**Tread:** That portion of a tire that comes into contact with the road.

**Tread Rib:** A tread section running circumferentially around a tire.

**Tread Separation:** Pulling away of the tread from the tire carcass.

**Tread Indicators (TWI):** The projections within the principal grooves designed to give a visual indication of the degrees of wear of the tread.

**Vehicle Capacity Weight:** The rated cargo and luggage load plus 68 kilograms (150 lbs.) times the vehicle's designated seating capacity.

**Vehicle Maximum Load on the Tire:** The load on an individual tire that is determined by distributing to each axle its share of the maximum loaded vehicle weight and dividing by two.

**Vehicle Normal Load on the Tire:** The load on an individual tire that is determined by distributing to each axle its share of the curb weight, accessory weight, and normal occupant weight (distributed in accordance with Table 1 of CRF 49 571.110) and dividing by 2.

**Weather Side:** The surface area of the rim not covered by the inflated tire.

**Wheel Center Member:** In the case of a non-pneumatic tire assembly incorporating a wheel, a mechanical device which attaches, either integrally or separably, to the non-pneumatic rim and provides the connection between the non-pneumatic rim and the vehicle: or, in the case of a non-pneumatic tire assembly not incorporating a wheel, a mechanical device which attaches, either integrally or separably, to the non-pneumatic tire and provides the connection between tire and the vehicle.

**Wheel-Holding Fixture:** The fixture used to hold the wheel and tire assembly securely during testing.

## Trailer Terminology

**Aft:** A nautical expression referring to the back area of a boat.

**Actuator:** See "Trailer Actuator"

**Anchor Chock:** A bracket or roller usually mounted on the front of the boat and often sticking forward past the bow of the boat.

**Back-Up Solenoid:** An electrical solenoid used on brake actuators for trailers with disc brakes that allows the trailer to be backed up on level ground without the brakes locking up.

**Bearing Protector:** A device that is installed on the hub that allows lubrication of the bearings.

**Boat Bow Safety Chains:** Safety chain(s) are attached to the winch stand of the trailer and hooked onto the bow eye of the boat as a safety precaution. (See *Safety Chains*)

**Boat Strakes:** Small ribs on the underside of the boat running fore and aft, visible from the underside of the boat.

**Boom:** The main frame members that run fore and aft on the trailer.

**Bow:** The front tip of the boat.

**Bow Eye Length:** A measurement taken from the transom to the bow eye for purposes of determining trailer length and winch stand placement.

**Bow Pulpit:** A small platform sticking forward past the tip of the bow of the boat.

**Bow Stop Roller:** A roller on the trailer's winch stand that the bow of the boat rest against.

**Brackish Water:** Polluted water or mixed freshwater and saltwater.

**Brake Controller:** An electrical brake controller mounted inside the cab of the tow vehicle that lets you manually activate the brakes and also houses the inertia sensing device. (See *Inertia Sensing Device*)

**Brake Flush Kit:** A garden hose adapter kit that attaches to drum brakes that allows fresh water to be flushed into the drum brakes to rinse out salt water, brackish water or small debris.

**Bunks:** Generally made of wood covered with carpet. Provides the main support under the boat's hull while on a bunk style trailer.

**Channel Glide Bunk Covers:** A slippery channel shaped plastic like material that goes over the existing wood bunk to make launching and loading the boat easier by reducing friction between the boat and the carpeted bunk.

**Coupler:** See "Trailer Coupler"

**Coupler Locking Device:** A lock or small nut & bolt through the locking hole on the latch of the coupler that helps to prevent the coupler from coming off the hitch ball.

**Coupler Safety Chains:** Safety chains running from the coupler or actuator area on the trailer to the hitch area of the tow vehicle.

**Fishtailing:** The boat and trailer swaying from side to side while being towed.

**Fore:** A nautical term referring to the front area of the boat.

**Gross Vehicle Weight:** The actual combined weight of the trailer, boat with motor, fuel and gear.

**Gross Vehicle Weigh Rating (GVWR):** The maximum allowable combined weight of the trailer, boat, motor, fuel and gear.

**Hitch Ball:** The ball shaped part of the hitch on the rear of the tow vehicle used to connect to the trailer.

**Hydraulic Surge (Disc Brakes):** Disc brakes on the trailer

using the hydraulic surge method to apply the brakes.

**Hydraulic Surge (Drum Brakes):** Drum brakes on the trailer using the hydraulic surge method to apply the brakes.

**I-Tube:** An unique extra extrusion is added to the aluminum tube to help protect and hide the wiring and brake lines inside the non-corrosive environment.

**Inertia Sensing Device:** This is part of an electrical unit used with electric brakes that senses the vehicle slowing down and activates the trailer brakes automatically. It is generally mounted inside the cab of the tow vehicle. (See *Brake Controller*)

**Keel:** The fore and aft center line of the boat, the lowest point of the hull on a V-bottomed boat.

**Launch Position:** Having the trailer deep enough in the water that if the boat were launched it would have enough water to support the boat without making contact with the ground or cause any damage.

**Load Guides:** Attachments to the side of the trailer that have rollers, bunks or PVC tubes that are near the side of the boat to assist in keeping the boat centered on the trailer while loading or launching.

**Mooring Line:** A rope or line attached to the bow of the boat so that a person has control of the boat after it is launched off the trailer.

**Port:** A nautical directional term for left or left side.

**Roller Pattern:** The spacing the rollers have on the underside of the boat on roller trailers.

**Rollers:** Round cylindrical rolls that support the boat and roll when the boat is being launched or loaded on a roller style trailer.

**Safety Chains or Cables:** A general term used to describe either the safety chains located on the winch stand that attach to the bow eye of the boat, or located near the coupler or actuator and attach near the hitch area of the tow vehicle.

**Saltwater:** Water with salt content in it.

**Side Rollers:** Refers to roller style load guides. (See *Load Guides*)

**Spindle Nut:** The nut that threads onto the spindle of the axle.

**Spindle Nut Retainer:** A steel cap that fits over the spindle nut used in conjunction with a cotter pin to keep the spindle nut from unscrewing.

**Spring Suspension:** The springs work together to provide an absorption for the boat and trailer during towing. The springs come in many different applications depending on the capacity rating required.

**Starboard:** A nautical directional term for right or right side.

**Stern:** A nautical expression referring to the back end of the boat.

**Swing Tongue:** A tongue installed on a trailer that has the ability to fold so that the length of the trailer would be shortened for storage.

**Tie-downs:** A securing device that attaches to or near the rear transom of the boat and downward to the trailer to help secure the back end of the boat to the trailer.

**Tongue:** The most forward portion of the trailer that has the coupler or actuator attached to it.

**Tongue Weight:** The amount of weight the tongue is carrying if weighed at the actuator or coupler.

**Torsion Axle Trailer:** A trailer using torsion as a means of suspension rather than leaf springs.



## Trailer Terminology

**TrailTow Vehicle:** The vehicle that pulls the boat and trailer.

**Trailer Actuator:** The part of the trailer that is bolted or welded to the tip of the tongue of the trailer that houses the hydraulic reservoir and several other components of a hydraulic brake system. This also is the part that attaches to the hitch ball on the tow vehicle.

**Trailer Coupler:** The part of the trailer that is bolted or welded to the tip of the tongue of the trailer and attaches to the hitch ball of the tow vehicle.

**Trailer Tongue:** See "Tongue"

**Transom:** The near vertical rear end of the boat where the outboard motor is generally attached, or the lower unit of the inboard outboard motor is generally attached.

**Transom Drain Plugs:** Plugs in the lower rear transom area that when removed will drain excess water from the boat after the boat is out of the water on the trailer. Drain plugs must be kept in the transom drain plug holes whenever the boat is in the water.

**Tuff Coat:** A professionally sprayed-on polyurethane finish that protects the trailer from rock chips and nicks.

**Vee Block:** A "V" shaped block on the trailer's winch stand that the bow of the boat rests against.

**Underwater Launching Lights** This is an optional feature for most EZLC trailers. This system works off a sensor installed on the rear of the trailer that works as a ground and as the trailer backs into the water, the lights go on and light up the bunk like a runway and turn off immediately when the trailer exits the water. Set usually consist of 3 lights on each of the two rails.

**Weight Carrying Hitch:** A hitch that distributes some of the weight of the boat and trailer into the frame of the tow vehicle.

**Winch Latch Assembly:** A latch assembly located on the winch that switches the winch from a "reel-in" condition to a "reel-out" or a "neutral free-wheeling" condition.

**Winch Safety Chains:** See "Boat Bow Safety Chains"

**Winch Strap/Cable:** A cable or strap attached to the trailer winch used in loading, launching and securing of the boat.

**60 degree Cone Angle Zinc Plated Lug Bolts:** A 60 degree lug bolt used to attach the wheel to the hub or drum on a trailer.

## Replacement of Manufacturers Certificate of Origin (MCO) or Vehicle Identification Number (VIN) Tags

For your protection, never purchase a used EZLC trailer without securing a state or province issued Certificate of Title properly transferred to you as the purchaser of the trailer by the legal owner. If the trailer has not been registered or is registered in a non-title issuing state, an MCO and/or other proof of ownership of the seller should be obtained. Before taking delivery of the trailer, verify that the VIN number of the trailer per the title or MCO matches the VIN

number on the tag located on the inside front rail of the trailer. EZLC will only replace MCOs for trailers that are less than two years old and that are owned by the first retail purchaser of the trailer. VIN tags may be replaced under certain circumstances. Certain documentation will be required before issuing a possible replacement. There is a fee for replacement of the VIN tag.

For information regarding a replacement of an MSO or VIN tag for trailers with a VIN beginning with **IL8** contact:

**cbeard@ezloader.com**  
**870-481-5138 ext. 224**

If the VIN begins with **IZE OR 4WS** contact: **jscribner@ezloader.com**  
**509-489-0181 ext. 238**

## Canadian Registration Recall Clearance Document

If you are exporting a custom welded trailer into Canada with a VIN number that begins with **IL8** or **1DH** and need this document call 870-481-5138 x224 or email cbeard@ezloader.com. There is a fee for 24 hour and 72 hour processing. If your trailer VIN number begins with **IZE** or **4WS** call 509-489-0181 x238.

## Additional Information

The following websites are provided for reference:

**Safe trailer towing** National Highway Traffic Safety Administration (NHTSA)  
**<http://www.nhtsa.dot.gov/cars/problems/Equipment/towing/>**

**Unique Functional Products (UFP)**  
**[www.ufpnet.com](http://www.ufpnet.com)** or **800-835-9211**.

**Trailer components such as actuators, axles, brakes, etc.**

**Carlisle Tire** **[www.carlisletire.com](http://www.carlisletire.com)** or **800-827-1001-Tires and most wheels**  
Contact them regarding **wear and warranty questions**.

**Fulton Performance Products** Jacks and non brake couplers visit  
**[www.fultonperformance.com](http://www.fultonperformance.com)**.

**Optronics, Inc.** Lighting components visit  
**[www.optronicsinc.com](http://www.optronicsinc.com)**

### Warranty Registration

EZ Loader has an easy to fill out trailer registration form on their web site. Click on the upper right side of the web page under “**Register Your Trailer**” at **www.ezloader.com**. Having your trailer on file will speed up the process if you have a problem, need replacement parts, or if we need to contact you with important information about your trailer. Using the Vehicle Identification Number (VIN) we can look up the registration which has the information we would need to make sure that you get the right parts for your trailer. Please ask your EZ Loader Dealer or give us a call if you have any question regarding the Warranty Card. Keep the upper portion of the card for your records. If you do not have access to a computer, send in the lower half to the following address:

#### Custom Welded Trailers

#### New Owner Warranty Registration

**EZ Loader Custom Boat Trailers, Inc**

**PO Box 270**

**Midway Arkansas 72651-0270**

**870-481-5138**

### Warranty Questions

If your EZ Loader boat trailer does not live up to our warranty, we want to make it right. Discuss the problem first with your EZ Loader Dealer. In most cases, a satisfactory solution can be resolved.

Manufacturers of marine products are required to keep current owner registration lists. If there is a safety modification or product recall, we will be able to notify you accordingly.

### IMPORTANT NOTICE

Laws regarding towing and trailers vary from state to state, make sure you are in full compliance with the laws in your area regarding trailer brakes, coupler requirements, safety chains, trailer width requirements, trailer lights, etc. Contact your state motor vehicle department for more information. Also, check with your automotive dealer or vehicle's owner's manual to make sure you have the proper towing vehicle, hitch and ball for the load you'll be pulling.

### Reporting Safety Defects

Manufacturer

**EZ Loader Custom Boat Trailers, Inc.**

**PO Box 270**

**Midway Arkansas**

If you believe that your vehicle has a defect which could cause a crash or could cause injury or death, you should immediately inform the National Highway Traffic Safety Administration (NHTSA) in addition to notifying **EZ Loader Boat Trailers**.

If NHTSA receives similar complaints, it may open an investigation, and if it finds that a safety defect exists in a group of vehicles, it may order a recall and remedy campaign. However, NHTSA cannot become involved in individual problems between you, your dealer, or EZ Loader Custom Boat Trailers.

To contact NHTSA you may either call the Vehicle Safety Hotline toll-free at 1-888-327-4236

(TTY: 1-800-424-9153),

<http://www.safercar.gov>, or write to:

**Administer**

**NHTSA**

**1200 New Jersey Avenue S.E.**

**Washington, DC 20590**

You can also obtain other information about motor vehicle safety from <http://www.safecar.gov>.

### Contact Information

Customer Service Department

**EZ Loader Custom Boat Trailers, Inc.**

**PO Box 270**

**Midway Arkansas 72651-0270**

**870-481-5138**

**Warranty ext.239**

**[customwarranty@ezloader.com](mailto:customwarranty@ezloader.com)**

**Parts ext.254**

**[customparts@ezloader.com](mailto:customparts@ezloader.com)**

**E-Store**

**[www.ezloader.com](http://www.ezloader.com)**

**Sales/Customer Service ext.224**

**[customsales@ezloader.com](mailto:customsales@ezloader.com)**



**For your records, please fill in the following information.  
It is important for future part or service requests.**

Model Year \_\_\_\_\_

Model Number \_\_\_\_\_

Serial Number (VIN) \_\_\_\_\_

Carrying Capacity \_\_\_\_\_

Date Purchased \_\_\_\_\_

Dealer Name \_\_\_\_\_

Dealer Address \_\_\_\_\_

Dealer Telephone \_\_\_\_\_

Tire Size \_\_\_\_\_

Recommended Tire Pressure \_\_\_\_\_

*If you sell your trailer: This manual must be transferred to the new owner. At the transaction, the original owner should photocopy this page, along with the name and address of the new owner and send it to:*

**CUSTOM WELDED TRAILERS**

New Owner Warranty Registration  
EZ Loader Custom Boat Trailers, Inc.  
PO Box 270  
Midway, AR 72651-0270  
870-481-5138

Original Owner \_\_\_\_\_

Address \_\_\_\_\_

City, State, Zip \_\_\_\_\_

New Owner \_\_\_\_\_

Address \_\_\_\_\_

City, State, Zip \_\_\_\_\_

***Warranty is not transferable to 2nd or other owners.***



### **LIMITED WARRANTY**

EZ Loader Custom Boat Trailers, Inc. warrants each new EZ Loader Custom Boat Trailer to be free from defects in materials and workmanship for a period of **5 years** from date of retail purchase or **6 years** from date of manufacture, whichever comes first., EZ Loader shall repair, or replace, without charge, any parts found to be defective because of imperfect workmanship or materials, within a reasonable time after the trailer is returned at purchaser's expense to any EZ Loader Custom Facility and/or depending on the severity to an authorized distributor or dealer. **Who is Covered:** This warranty is extended to the **original purchaser only** and does not extend to any other persons to whom the trailer may be transferred. **What is Not Covered:** Provisions of this warranty shall not apply to any product which is found to have been modified or altered in any way; nor shall the warranty apply to any defect or malfunction which was caused by damage, unreasonable use, or failure to provide reasonable and necessary maintenance. The warranty will not cover damage cause by overloading the trailer beyond stated capacities located on the VIN Identification label located on the front of the inside rail of the trailer, improper adjustment of the trailer to the boat or the use of weight distribution hitches in conjunction with hydraulic surge brakes. Due to the highly corrosive conditions a trailer is exposed to, and even after utilizing one of the highest quality finishes, **rust formation is not covered**. This limited warranty does not cover winches, lights, couplers, actuators, brakes, tongue jacks springs and tires or wheels, as these items are **warranted separately by their manufacturer**. **Other Limitations:** Races, grease type bearings and seals are covered for 90 days, while the Vault™ bearing system is warranted for 5 years from date of purchase or 6 years from manufacturing date. Any implied warranties, obligations, or liabilities, including but not limited to, any implied warranty of merchantability, shall be limited in duration to the six-year duration of this written limited warranty. Some states do not allow limitation on how long an implied warranty lasts, so the above limitation may not apply to you. The use of any unit as part of a rental fleet, or use for commercial purposes, voids this warranty. The following are exclusions of EZ Loader Custom Warranty: Loss of time, inconvenience, towing charges, travel expenses, lodging, telephone, gas, loss or damages to personal property or loss of wages. This warranty is intended to comply with the "Magnusson-Moss Warranty Federal Trade Commission Improvement Act" and any provisions of this warranty or actions taken by EZ Loader Custom Boat Trailers pursuant to this warranty shall be construed accordingly. EZ Loader Boat Trailers, Inc. shall not be liable for any incidental or consequential damages for breach of this or any other warranty, express or implied. Some states do not allow the exclusion of limitation of incidental or consequential damages, so the above limitation or exclusion may not apply to you. The 5 year from retail sale/ 6 year from manufacturing date warranty went into effect 7/1/12 on boat trailers.

**Register your trailer at [www.ezloader.com](http://www.ezloader.com)**

(Select Warranty Registration) *It is important that all trailers are registered in case of any recall which may occur with components of the trailer.*

**EZ Loader Custom Boat Trailers, Inc.**  
**6533 Hwy 126 North ♦ PO Box 270**  
**Midway, Arkansas 72651-0270**  
**870-481-5138 ♦ [www.ezloader.com](http://www.ezloader.com)**  
**Parts Dept: X 254 [customparts@ezloader.com](mailto:customparts@ezloader.com)**  
**Warranty Dept: X239 [customwarranty@ezloader.com](mailto:customwarranty@ezloader.com)**

©EZ Loader Custom Boat Trailers, Inc. 131903